

⇒ Programming Procedure

Level-1 (User Level)

Press **SET** key for 2-3 secs. to enter this mode.

The display shows:

S E t
1 0 0 0

Note that the leftmost digit will be blinking.

To change the parameter, to say '2500' follow the steps as given:

- 1) First press the shift key '◀' until the blinking shifts to the hundredth place.
- 2) Press the increment key '▲' till the digit shows 5. the display will now show the following :

S E t
1 5 0 0

- 3) Now press the shift key '◀' again to shift the blinking to the last digit.
- 4) Repeat step 2 to increment the last digit to '2'. Now the display will show the required value:

S E t
2 5 0 0

- 5) Now, once the required value is displayed, press set key to save the new value and exit the setting mode. Now the unit will go into the standby mode where the upper display will show the process count and the lower display will show the new set count.

Level-2 (Configuration Level)

To enable the configuration Level, press and hold '▲' and '◀' keys for 3 to 4 seconds. The upper display will show 'Cont' and the lower display will show 'Yes' or 'no' message. Now set the lower display to 'Yes' by pressing the '▲' key and press 'SET' key to revert back to the normal mode. Now press 'SET' key for 2 to 3 seconds to show the set counts parameter. After setting the set counts (level-1) pressing SET key again will show the configuration level parameters. Press the '▲' and '◀' keys (similar to level-1) to change the parameters and 'SET' key to scroll to the next parameter. After the last parameter is set, the unit will come out of the configuration level on pressing the 'SET' key. The various parameters displayed are described as follows:

Displayed code on the upper display	Description of code	Limits		Description
		Min.	Max.	
S E t	Set counts	0001	9999	When the process counts reach this count, the relay turns ON.
M o d E	Auto/Manual Selection	Auto	Man	If set to Auto the relay will automatically turn Off after a specific time delay as set by the
t M r	Timer	0001	0099	Valid only if 'Mode' is set to 'auto'. The time (in seconds) after which the relay turns off.
P u L S	Pulse count	0001	0099	Determines the no. of input pulses required to increment the process value by one count.
b c n t	Batch count	0000	9999	Shows the no. of batches completed. Increments once each time the process value
t -	Total counts	000000	999999	Total counts are the total no. of counts of all the batches.

Note:

1. The second parameter 'Mode' has only two values which can be toggled between 'Auto' and 'Man' by pressing the '▲' key. The '◀' key does not work for this parameter.
2. The last parameter 't-' shows the total counts in a six digit figure. The most significant two digits are shown on the right side of the 't-' message and the other four least significant digits are shown in the lower display.

For example if the last parameter is displayed as follows:

t - 1 2
3 4 5 6

Then the total counts should be interpreted as 123456 counts.

3. The RST key when pressed for 3-4 seconds only resets the process counts to 0000 and does not affect the total and batch counts.
4. To reset the total counts and batch counts, press and hold the '▲' and 'RST' keys for about 8 to 9 seconds until a momentary message 'Cnt' and 'rst' are displayed on the upper and lower displays respectively.

⇒ Front Panel Description

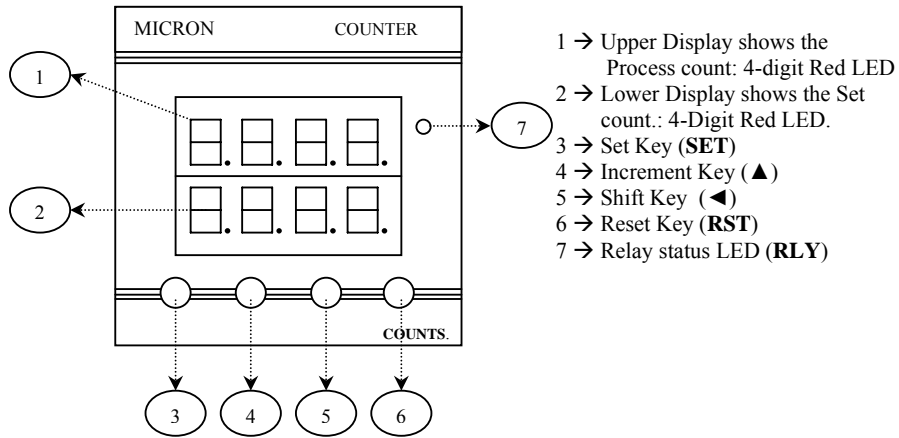

⇒ External Wiring Diagram:

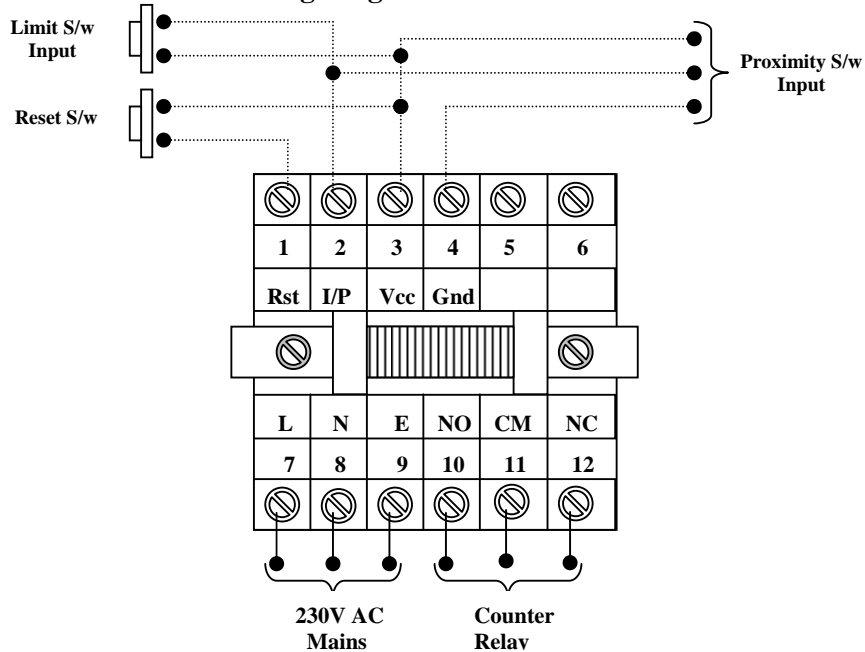

MICRON



Microcontroller based Batch Counter Instruction Manual

⇒ Introduction

This micro-controller based counter is mainly designed taking into consideration a simplicity in operation without sacrificing the functional capability and features of a standard counter. A rugged, reliable but economical design makes it a sure choice for innumerable counter-based applications and will provide trouble-free operation for a long time. Apart from the standard counter logic, this counter also has the unique feature of *auto resetting* of the count and relay after a predetermined time delay which is settable from 1 to 99 seconds. An additional feature of setting the no. of pulses/count is also incorporated. In addition, there are two more parameters Batch count and Total counts which can be viewed but not modified. The batch counts signify the no. of batches completed (i.e. the no. of times the process count reached the set counts.) and the total counts signify the total no. of counts of all the batches.

⇒ Specifications

- | | | |
|---------------------------------|---|--|
| 1. Range | : | Process Counts : 0000 ~ 9999 counts
Set counts : 0001 ~ 9999 counts
Timer : 0001 ~ 0099 seconds
Pulse counts : 0001 ~ 0099 pulses/count
Batch counts : 0000 ~ 9999 counts
Total counts : 000000 ~ 999999 counts |
| 2. Input | : | Proximity or Limit S/w Trigger Input (selectable) |
| 3. Process count storage | : | memory retention of last count even on power failure |
| 4. Reset Facility | : | Through potential free contacts on backplate OR on the front by pressing RST key for 2~3 seconds. |
| 3. Memory Retention | : | About 100 years (including Process count) |
| 4. Power Supply | : | 230V AC, 50Hz. ± 10% |
| 5. Relay | : | Relay 1C/o, 5A, 230V AC resistive contacts |
| 6. Cutout Dimensions | : | 68mm(H) x 68mm(W) |
| 7. Overall Dimensions | : | 72mm(H) x 72mm(W) x 113mm(D) |